



Designation: D2843 – 22

# Standard Test Method for Density of Smoke from the Burning or Decomposition of Plastics<sup>1</sup>

This standard is issued under the fixed designation D2843; the number immediately following the designation indicates the year of original adoption or, in the case of revision, the year of last revision. A number in parentheses indicates the year of last reapproval. A superscript epsilon ( $\epsilon$ ) indicates an editorial change since the last revision or reapproval.

*This standard has been approved for use by agencies of the U.S. Department of Defense.*

## 1. Scope\*

1.1 This fire-test-response test method covers a laboratory procedure for measuring and observing the relative amounts of smoke obscuration produced by the burning or decomposition of plastics. It is intended to be used for measuring the smoke-producing characteristics of plastics under controlled conditions of combustion or decomposition. Correlation with other fire conditions is not implied. The measurements are made in terms of the loss of light transmission through a collected volume of smoke produced under controlled, standardized conditions. The apparatus is constructed so that the flame and smoke is observable during the test.<sup>2</sup>

1.2 During the course of combustion, gases or vapors, or both, are evolved that are potentially hazardous to personnel. Adequate precautions shall be taken to protect the operator.

1.3 The values stated in SI units are to be regarded as the standard. The values given in parentheses are for information purposes only.

1.4 *This standard is used to measure and describe the response of materials, products, or assemblies to heat and flame under controlled conditions, but does not by itself incorporate all factors required for fire hazard or fire risk assessment of the materials, products, or assemblies under actual fire conditions.*

1.5 *Fire testing is inherently hazardous. Adequate safeguards for personnel and property shall be employed in conducting these tests. Specific safety warning statements are given in 1.2 and 9.13.*

1.6 *This standard does not purport to address all of the safety concerns, if any, associated with its use. It is the responsibility of the user of this standard to establish appro-*

*priate safety, health, and environmental practices and determine the applicability of regulatory limitations prior to use.*

NOTE 1—There is no known ISO equivalent to this standard.

1.7 *This international standard was developed in accordance with internationally recognized principles on standardization established in the Decision on Principles for the Development of International Standards, Guides and Recommendations issued by the World Trade Organization Technical Barriers to Trade (TBT) Committee.*

## 2. Referenced Documents

### 2.1 ASTM Standards:<sup>3</sup>

- D618 Practice for Conditioning Plastics for Testing
  - D883 Terminology Relating to Plastics
  - D1600 Terminology for Abbreviated Terms Relating to Plastics
  - E84 Test Method for Surface Burning Characteristics of Building Materials
  - E176 Terminology of Fire Standards
  - E456 Terminology Relating to Quality and Statistics
  - E662 Test Method for Specific Optical Density of Smoke Generated by Solid Materials
  - E691 Practice for Conducting an Interlaboratory Study to Determine the Precision of a Test Method
  - E906/E906M Test Method for Heat and Visible Smoke Release Rates for Materials and Products Using a Thermopile Method
  - E1354 Test Method for Heat and Visible Smoke Release Rates for Materials and Products Using an Oxygen Consumption Calorimeter
  - E2935 Practice for Evaluating Equivalence of Two Testing Processes
- ### 2.2 ISO Standards:<sup>4</sup>
- ISO 13943 Fire Safety—Vocabulary

<sup>1</sup> This test method is under the jurisdiction of ASTM Committee D20 on Plastics and is the direct responsibility of Subcommittee D20.30 on Thermal Properties (Section D20.30.03).

Current edition approved March 15, 2022. Published March 2022. Originally approved in 1970. Last previous edition approved in 2019 as D2843 - 19. DOI: 10.1520/D2843-22.

<sup>2</sup> Anonymous, "A Method of Measuring Smoke Density," *NFPA Quarterly*, QNFPA, Vol 57, January 1964, p. 276. Reprint NFPA Q57-9. Available from NFPA, 60 Batterymarch St., Boston, MA 02110.

<sup>3</sup> For referenced ASTM standards, visit the ASTM website, [www.astm.org](http://www.astm.org), or contact ASTM Customer Service at [service@astm.org](mailto:service@astm.org). For *Annual Book of ASTM Standards* volume information, refer to the standard's Document Summary page on the ASTM website.

<sup>4</sup> Available from International Organization for Standardization (ISO), ISO Central Secretariat, BIBC II, Chemin de Blandonnet 8, CP 401, 1214 Vernier, Geneva, Switzerland, <http://www.iso.org>.

\*A Summary of Changes section appears at the end of this standard

### 3. Terminology

3.1 *Definitions*—For definitions of terms relating to plastics, the definitions in this test method are in accordance with Terminology **D883** and **D1600**. For terms relating to fire, the definitions in this test method are in accordance with Terminology **E176** and ISO 13943. In case of conflict, the definitions given in Terminology **E176** shall prevail. For terms relating to precision and bias and associated issues, the terms used in this test method are in accordance with the definitions in Terminology **E456**.

### 4. Summary of Test Method

4.1 The test specimen is exposed to flame for the duration of the test, and the smoke is substantially trapped in the chamber in which combustion occurs. A 25 by 25 by 6-mm (1 by 1 by ¼-in.) specimen is placed on supporting metal screen and burned in a laboratory test chamber (**Fig. 1**) under active flame conditions using a propane burner operating at a pressure of 276 kPa (40 psi). The 300 by 300 by 790-mm (12 by 12 by 31-in.) test chamber is instrumented with a light source, photoelectric cell, and meter to measure light absorption horizontally across the 300-mm (12-in.) light beam path. The chamber is closed during the 4-min test period except for the 25-mm (1-in.) high ventilation openings around the bottom.

4.2 The light-absorption data are plotted versus time. A typical plot is shown in **Fig. 2**. Two indexes are used to rate the material: the maximum smoke produced and the smoke-density rating.

### 5. Significance and Use

5.1 Tests made on a material under conditions herein prescribed are of considerable value in comparing the relative smoke obscuration characteristics of plastics.

5.2 This test method serves to determine the extent to which plastic materials are likely to smoke under conditions of active burning and decomposition in the presence of flame.

NOTE 2—One study<sup>5</sup> suggested that visual and instrumental observations from this test compare well with the visual observations of the smoke generated by plastic materials when added to a freely burning large outdoor fire.

5.3 The usefulness of this test procedure is in its ability to measure the amount of smoke obscuration produced in a simple, direct, and meaningful manner under the specified conditions. The degree of obscuration of vision by smoke generated by combustibles is known to be affected by changes in quantity and form of material, humidity, draft, temperature, and oxygen supply.

5.4 *Safety Precautions*—Products of combustion are toxic. Care shall be taken to guard the operator from the effects of products of combustion.

### 6. Apparatus

6.1 The smoke chamber shall be constructed essentially as shown in **Fig. 1**.

#### 6.1.1 Chamber:

6.1.1.1 The chamber shall consist of a 14-gage (B & S or AWG) 300 by 300 by 790-mm (12 by 12 by 31-in.) aluminum box to which is hinged a heat-resistant glass glazed door. This box shall be mounted on a 350 by 400 by 57-mm (14 by 16 by 2¼-in.) base which houses the controls. Dependent upon the materials tested, the metal will require protection from corrosion.

6.1.1.2 The chamber shall be sealed except for 25 by 230-mm (1 by 9-in.) openings on the four sides of the bottom of the chamber. A 1700-L/min (60-ft<sup>3</sup>/min) blower shall be mounted on one side of the chamber. The inlet duct to the exhaust blower shall be equipped with a close-fitting hood damper. The outlet of the blower shall be connected through a duct to the laboratory exhaust system. If the chamber is in a ventilated hood, no connection to the lab exhaust system through a duct is needed.

6.1.1.3 The two sides adjacent to the door shall be fitted with 70-mm (2¾ in.) diameter smoke-tight glazed areas centered 480 mm (19¾ in.) above the base. At these locations and outside the chamber, boxes containing the optical equipment and additional controls shall be attached.

6.1.1.4 A removable white plastic plate shall be attached to the back of the chamber. There shall be a 90 by 150-mm (3½ by 6-in.) clear area centered 480 mm above the bottom of the chamber through which is seen an illuminated white-on-red exit sign. The white background permits observation of the flame, smoke, and burning characteristics of the material. The viewing of the exit sign helps to correlate visibility and measured values.

#### 6.1.2 Specimen Holder:

6.1.2.1 The specimen shall be supported on a 64-mm (2½-in.) square of 6 by 6-mm, 0.9-mm gage (¼ by ¼-in., 0.035-in. gage) stainless steel wire cloth 220 mm (8¾ in.) above the base and equidistant from all sides of the chamber. This screen shall lie in a stainless steel bezel supported by a rod through the right side of the chamber. From the same rod, a similar bezel shall be located 76 mm (3 in.) below, and it shall support a square of ¼-in. thick calcium silicate to catch particles that drip from the specimen during the test. At the conclusion of the test, rotate the specimen holder rod and quench the burning specimen in a shallow pan of water positioned below the specimen holder.

#### 6.1.3 Ignition System:

6.1.3.1 The specimen shall be ignited by a propane flame from a burner operating at a pressure of 276 kPa (40 psi). The fuel (**Note 3**) shall be mixed with air that has been propelled through the burner by the Venturi effect of the propane as it passes from a 0.13-mm (0.005-in.) diameter orifice (**Note 4**), and the burner shall be assembled as shown in the exploded view of the burner in **Fig. 3**. The burner shall be designed to provide adequate outside air.

NOTE 3—Commercial grade 85.0 % minimum, gross heating value 23 000 cal/litre (2590 Btu/ft<sup>3</sup>) propane meets the requirements.

NOTE 4—Since the orifice provides the metering effect proportionate to the supply pressure, care must be taken that the orifice is the only means of fuel egress.

6.1.3.2 The burner shall be capable of being positioned quickly under the specimen so that the axis of the burner falls

<sup>5</sup> Bartosic, A. J., and Rarig, F. J., "Evaluation of the XP2 Smoke Density Chamber," *Symposium on Fire Test Methods—Restraint & Smoke*, ASTM STP 422, ASTM, Philadelphia, PA, 1966.

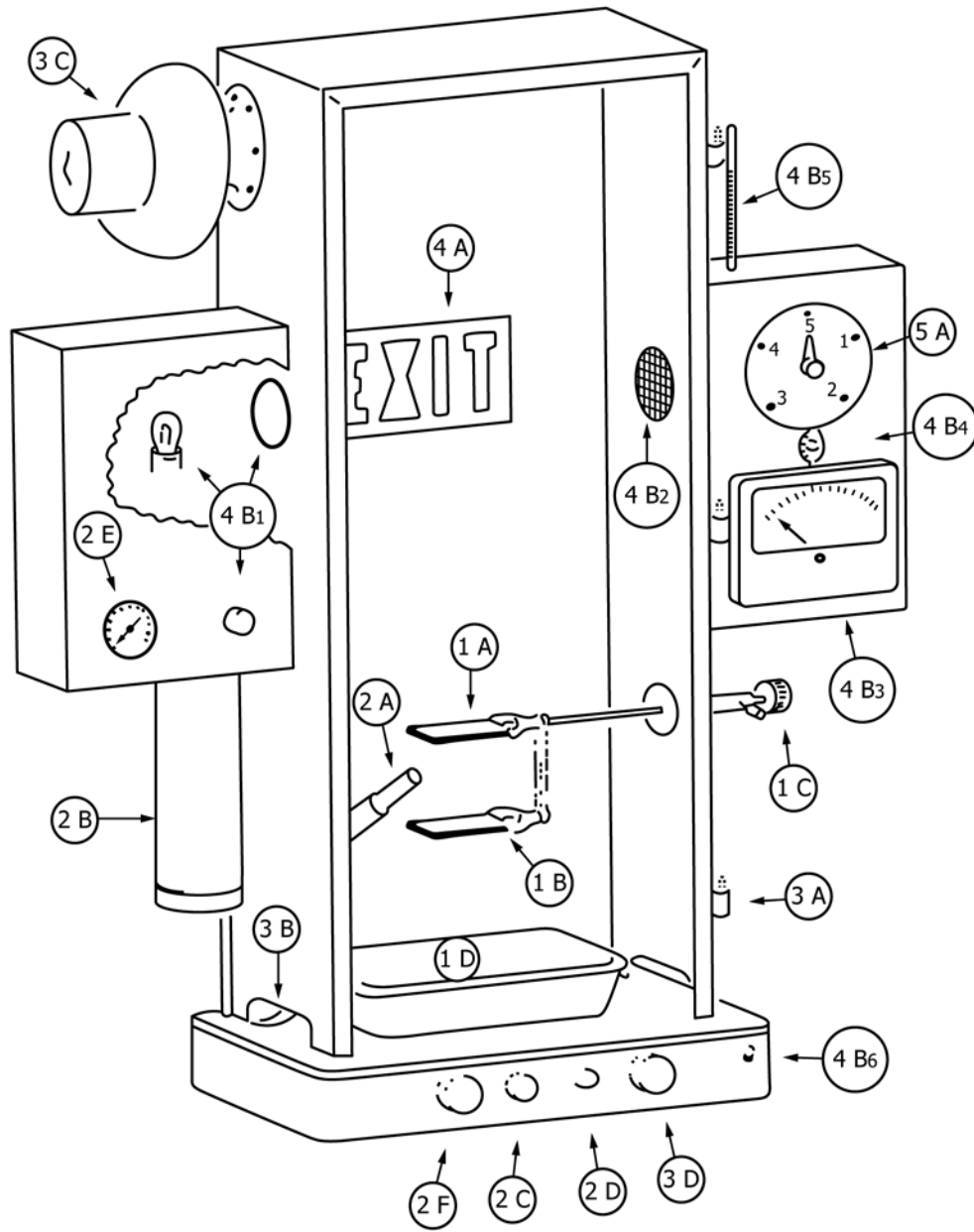

1. Specimen Holder
  - A Stainless steel screen
  - B Calcium-silicate sheet
  - C Adjusting knob
  - D Quench pan
2. Ignition
  - A Burner
  - B Propane tank
  - C Gas shut-off valve
  - D Pressure regulator adjustment
  - E Pressure indicator
  - F Burner-positioning knob
3. Cabinet (shown without door)
  - A Hinges (door gasketed three sides)
  - B Vents (25-mm (1-in.) high opening four sides)
  - C Blower (damper on mounting side)
  - D Control (blower on when damper is open)
4. Photometer
  - A Visual system (exit sign)
  - B Measuring system
    - 1 Light source and adjusting transformer
    - 2 Photronic cell and grid (to block stray light)
    - 3 Meter (indicating percent of light absorbed)
    - 4 Temperature compensation (if required)
    - 5 Photocell temperature monitor (if required)
    - 6 Range change
5. Timer
  - A Indicator, 0 to 5 min (friction reset)

FIG. 1 Schematic Diagram of Smoke Chamber